

MAHINDRA ADVENTURE RALLY OF MAHARASHTRA

A round of FMSCI Indian Rally Championship 2015



MAHINDRA ADVENTURE RALLY OF MAHARASHTRA 10th June to 14th June 2015

Round 2 of 2015 FMSCI Indian Rally Championship

Rally Office Postal Address

WESTERN INDIA SPORTS ASSOCIATION

SHOP NO. 2, GALAXY APARTMENT, OP. TIRUPATI TOWN, NEAR AKASHWANI CENTRE,
NASHIK- 422013.

T : +91 253 2316067, F : + 91 253 2316397

E : wisa.ind@gmail.com W: www.wisa.org.in

Rally Secretariat Address

From : Wednesday, 10th June, 2015 To : Sunday, 14th June, 2015

THE GATEWAY HOTEL

FULL POP-17, MIDC AMBAD, MUMBAI-AGRA ROAD NASHIK 422010.

T : +91-253-6603344, F : +91-253-6603366

E : -

Supplementary Regulations

Contents

1. Introduction	3
2. Organisation.....	3
3. Programme	5
4. Entries	7
5. Insurance.....	9
6. Advertising and Identification.....	10
7. Tyres.....	10
8. Fuel.....	10
9. Reconnaissance.....	11
10. Administrative Checks.....	12
11. Scrutineering, Sealing and Marking	13
12. Other Procedures.....	14
13. Identification of Officials.....	15
14. Prizes	16
15. Final Checks.....	16
Appendix 1 - Itinerary	17
Appendix 2 – Reconnaissance Schedule	179
Appendix 3 – Competitors Relations Officer(s) Itinerary and Photograph.....	21
Appendix 4.1 – Compulsory Advertisement	221
Appendix 4.2 – Optional Advertisement.....	232
Appendix 5 – Any Other.....	243

1. Introduction

- 1.1** This rally will be run in compliance with the FIA International Sporting Code and its appendices, the General Prescriptions of The Federation of Motor Sports Clubs of India (FMSCI), the relevant Regulations concerning Indian Rally championship, these Supplementary Regulations and bulletins issued by FMSCI.

The Federation of Motor Sports Clubs of India (FMSCI) is ASN of FIA in India.

This rally is inscribed on the FIA Calendar under Asia Zone. Asia Zone competitors may take part in this rally and accrue points.

Modifications, amendments and/or changes to these Supplementary Regulations will be announced only by numbered and dated bulletins (issued by the Organisers or the Stewards).

The 2015 FMSCI General Prescriptions can be found at www.fmsci.co.in

1.2 Road Surface

Special Stages : ASPHALT
Super Special Stage : ASPHALT

1.3 Overall SS distance and total distance of the itinerary

Special Stages : 110.37 Km
Super Special Stage : 006.09 Km
Liaison : 354.54 Km
Total Distance : 471.00 Km

2. Organisation

2.1 FMSCI titles for which the rally counts

- 2015 FMSCI Indian Rally Champion Driver
- 2015 FMSCI Indian Rally Champion Co Driver
- 2015 FMSCI Indian Rally Champion Team

- 2015 FMSCI Indian Rally Champion 2000 cc Driver
- 2015 FMSCI Indian Rally Champion 2000 cc Co-Driver
- 2015 FMSCI Indian Rally Champion 2000 cc Team

- 2015 FMSCI Indian Rally Champion 1600 cc Driver
- 2015 FMSCI Indian Rally Champion 1600 cc Co Driver
- 2015 FMSCI Indian Rally Champion 1600 cc Team

- 2015 FMSCI 1600 cc Cup Winner Driver
- 2015 FMSCI 1600 cc Cup Winner Co Driver
- 2015 FMSCI 1600 cc Cup Winner Team

2.2 FMSCI Permit / VISA numbers

IRC : T.B.A.
2000 : T.B.A.

1600 : T.B.A.
Cup : T.B.A.

2.3 Organiser's Name, Address and Contact details

Name of the Organising Club :	WESTERN INDIA SPORTS ASSOCIATION
National Sporting Authority :	The Federation of Motor Sports Clubs of India
Postal Address :	SHOP NO. 2, GALAXY APARTMENT, OP. TIRUPATI TOWN, NEAR AKASHWANI CENTRE, NASHIK- 422013. T :+91 253 2316067 F : + 91 253 2316397 E : wisa.ind@gmail.com W : www.wisa.org.in

2.4 Organisation committee

BURKULE Sameer	PANDIT Swati
WADWALKAR Rajeev	SINHA Niranjana
PATANI Nilesh	JOSHI Manoj
BHAMREY Nitin	AGHARKAR Sujay
SAKRIKAR Pranav	DESHPANDE Chinmay
TATAR Yogesh	AGHARKAR Suhas
DARYANI Pavan	AHIRE Ajay
GURNANI Kailash	MACHHE Kaustubh

2.5 Stewards of the Meeting

Chairman : KHAN ZAYN
Steward : COMMISSARIAT FAROKH
Steward : NAGARAJAN MOHAN
Secretary to Stewards : SAKRIKAR PRANAV

2.6 FMSCI Delegates & Observer

Observer : SHIVAPPA SHIVU
Technical Delegate : G SATHISH KUMAR

2.7 Senior officials

Clerk of the Course	BURKULE SAMEER
Deputy Clerk of the Course	KURTADIKAR ANIRUDDHA (ALPHA), SINHA NIRANJANA (BETA), GUJAR ANIL (GAMMA),
Assistant Clerk of the Course	YANDE SHREYAS
Chief Scrutineer	WAGHCHORE RAVI
Scrutineer/s	JOSHI MILIND , GAIKWAD AMAR
Competitor Relations Officer/s	GURNANI KAILASH , MACHHE KAUSTUBH
Chief Safety Officer	BHAMRE JEEVAN

Chief Medical Officer	DR. CHAVAN MANGESH
Media Relation Officer	KOTWAL SHREEPAD
Communication Chief	WADWALKAR RAJEEV
Results Coordinators	T.B.A.
Stage Commanders	ALPHA (SS 1/4/7) : PATIL SUNIL BETA (SS 2/5/8) : UPASANI ANIKET GAMMA (SS 3/6/9) : WADWALKAR ROHAN STAGE NAMES (SS NOS.) : NAME
Stage Safety Officers	ALPHA (SS 1/4/7) : BHAMARE NILESH BETA (SS 2/5/8) : SHIMPI AVINASH GAMMA (SS 3/6/9) : GAJJAR DIGANT STAGE NAMES (SS NOS.) : NAME
SECRETARY OF MEET	SAKRIKAR PRANAV
SERVICE PARK MANAGER	TATAR YOGESH
CHIEF TIME KEEPER	KULKARNI SANJAY

2.8 HQ location and contact details (tel. & fax.)

THE GATEWAY HOTEL

FULL POP-17, MIDC AMBAD, MUMBAI-AGRA ROAD NASHIK 422010.

T : +91-253-6603344 F :+91-253-6603366

E :-

3. Programme

Entries Open on the publication of these Supplementary Regulations.

Date (2015)	Time (hrs)	Venue	Particulars
SUNDAY 31 MAY	20:00	RALLY OFFICE	Closing Date for Standard Entries
TUESDAY 02 JUNE	18:00	RALLY OFFICE	Closing Date for Late Entries
WEDNESDAY 03 JUNE	18:00	RALLY OFFICE	Publication of Entry List
WEDNESDAY 10 JUNE	14:00	RALLY HQ	Rally Office Opens
			Media Centre Opens
	15:00 - 21:00	RALLY HQ	Issue of Road Map, Map & Rally Guide
			Collection of Competition Number Plates, Optional Advertising Stickers
			Registration of Reconnaissance

MAHINDRA ADVENTURE RALLY OF MAHARASHTRA

			Vehicle
	21:30	RALLY HQ	Media Centre Closes
			Rally Office Closes
THURSDAY 11 JUNE	05.30	RALLY HQ	Rally Office Opens
			Administrative Cheks
	06:00 - 10:30	CITY CENTRE MALL	Pre Event Scrutineering (Refer Art.11.1 of SR)
	06:00 - 13:00		Reconnaissance – SS,(ETA of Last Car to finish in Nashik at 14:30Hrs. Refer Appendix II of SRs.)
	11:00	RALLY HQ	Media Centre Opens
	14:00	RALLY HQ	Publication of Start List for Cermonial Start
	14:30 - 15.15	DADSAHEB PHALKE SMARAK	Reconnaissance – SSS
	15:30	CITY CENTRE MALL	Pre Event Press Conference - By Invitation Only
	16:45	CITY CENTRE MALL	Parc Ferme Opens for Ceremonial Start
	17:00	CITY CENTRE MALL	Compulsory Drivers Briefing
	18:00	CITY CENTRE MALL	Ceremonial Start
	20:00	RALLY HQ	1st Stewards Meeting
	20:30	RALLY HQ	Publication of Start List for Leg 1
	21:30	RALLY HQ	Media Centre Closes
			Rally Office Closes
FRIDAY 12 JUNE	06:00	RALLY HQ	Rally Office Opens
	06:30	CITY CENTRE MALL	Start of Leg 1 Sec 1
	11:00	RALLY HQ	Media Centre Opens
	19:21	CITY CENTRE MALL	Parc Ferme closes for all cars excepting for Super Rally Format
	19:45	RALLY HQ	Publication of Start List for Leg 2, Sec 4
			Publication of Start List for Leg 2, Sec 6/7/8
	21:00	RALLY HQ	Media Centre Closes
			Rally Office Closes
SATURDAY 13 JUNE	07:00	CITY CENTRE MALL	Parc Ferme closes for Super Rally Format Cars
	07:30	RALLY HQ	Rally Office Opens
	08:00	CITY CENTRE MALL	Start of Leg 2 Sec 4
	11:00	RALLY HQ	Media Centre Opens
	15:19	DADASAHEB PHALKE SMARAK	Start of Leg 2 Sec 6
	17:49	CITY CENTRE MALL	Parc Ferme closes for all cars

	20:00	RALLY HQ	Media Centre Closes
			Rally Office Closes
SUNDAY 14 JUNE	08:00	RALLY HQ	Rally Office Opens. Media Centre Opens.
	08:40	CITY CENTRE MALL	Start of Leg 2 Sec 8 / 9
	12:42	THE GATEWAY HOTEL	Transit Parc Ferme Closes for all Classified Cars
	12:45	THE GATEWAY HOTEL	Podium Finish & Champagne Shower Ceremony
	13:15	THE GATEWAY HOTEL	Post Event Press Conference
	13:45	CITY CENTRE MALL	Post Event Final Scrutineering
	13:45	CITY CENTRE MALL	Finish Park Ferme closes for all Classified cars
	16:15	THE GATEWAY HOTEL	Publication of Provisional Final Classification
	19:30	THE GATEWAY HOTEL	Media Centre Closes. Rally Office Closes.

4. Entries

4.1 Closing Date of Entries

Standard Entries : SUNDAY 31 MAY, 2015 @ 20:00 hrs

Late Entries : TUESDAY 02 JUNE @ 18:00 hrs

4.2 Entry Procedure

Those wishing to take part in the MAHINDRA ADVENTURE RALLY OF MAHARASHTRA must send the duly completed official entry form (including Co-Driver details) to the Club address given in Art.2.3.

If the entry is sent by Fax or email, the original must reach the organizers at the latest, two days after the final date of close of standard entries.

4.3 Number of Entrants / Competitors Accepted and Classes

The maximum number of entries is 40. If more than 40 entries are received, the organizers reserve the right to extend this number and to decide which entries will be accepted.

Entries will be grouped in to:

Only Saloon cars/SUVs are permitted.

a) Up to 3500 cc (including Turbo Factor)

- Group N, Group N4, R2B
- FMSCI license holders & Other Asia Zone ASN License holders with points
- Others without points
- FIA / FMSCI homologated cars
- Compete for overall

MAHINDRA ADVENTURE RALLY OF MAHARASHTRA

NOTE : The FMSCI homologated cars will follow the FMSCI Group N Technical / Safety Regulations. The FIA homologated cars will follow the FIA Group N Technical / Safety Regulations. In the case of N4, vehicles may follow either FIA Group N or FMSCI N4 Regulations. The class will compete only for overall classification.

- b) Up to 2000 cc
- Group N, 2WD
 - FMSCI license holders & Other Asia Zone ASN License holders with points
 - Others without points
 - FMSCI homologated cars
 - Compete for IRC 2000 class & overall
- c) Up to 1600 cc
- Group N, 2WD
 - FMSCI License holders only.
 - FMSCI homologated cars
 - Compete for IRC 1600 class & overall
- d) FMSCI 1600 cc Cup
- Group N, 2WD
 - FMSCI License holders only
 - FMSCI homologated cars prior to 31st December 2007
 - Compete for 1600 cc Cup, IRC 1600 cc & overall

4.4 Entry Fees

4.4.1 Standard Entries : SUNDAY 31 MAY, 2015 @ 20:00 hrs

Championship	With Optional Advertisement	Without Optional advertisement
IRC	` 30,000/-	Rs.50,000/= additional
IRC 2000 cc	` 22,000/-	
IRC 1600 cc	` 17,000/-	
FMSCI 1600 Cup	` 17,000/-	

Minimum 4 cars require to form class

Team Entrant Manufacturer : `20,000/- (Additional – per car)

Team Entrant Others : NIL (Additional – per car)

Manufacturer : Any Automobile / ancillary manufacturer

Team should consist of minimum of 2 cars and maximum of 4 cars per championship.

4.4.2 Late Entries : TUESDAY 02 JUNE @ 18:00 hrs

Additional Fees : Rs.5000/=

4.4.3 All entry and other fees are inclusive of Taxes applicable in India.

4.4.4 The entry fee includes:

Item	Numbers
Service Vehicle Plates	2
Supplementary Regulations	1
Road Book/s	1
Service Manual	1
Route Map	1
Team Passes	6
Guest Passes for SSS	2
Service Area Cafeteria passes	2
Service Park Area (size of bay)	6.5M x 2.5M

The organizer may not provide tents for your service bay. In case you require organizers tent, the rate per Sq.Ft. is Rs. 100/-.

4.5 Payment details

Payment of entry fees can be made by either by Demand Draft in favour of WESTERN INDIA SPORTS ASSOCIATION payable at NASHIK or by Cash or by wire transfer

Bank : STATE BANK OF HYDERABAD
 IFSC Code : SBHY0020826
 Branch : NASHIK BRANCH (20826)
 Branch Code :
 Account / No. : Current 62196093013

4.6 Refunds

Entry fees will be refunded in full only:

- To candidates whose entry has not been accepted
- In the case of the rally not taking place

The Organisers may refund 50% of the entry fee to those competitors who, for reasons of "Force Majeure" (duly accepted by the organizing committee), were unable to start in the Rally.

5. Insurance

5.1 Description of Insurance Cover Provide by FMSCI with Permit

Third Party Public Liability for Rs.50 lakhs valid during the running of the event only.

Competitors : A maximum of 150 competitors with valid FMSCI Competition License participating in various events across the Country on a given day are covered for Personal Accident Insurance for Rs. 5 lakhs with Rs. 1 Lakh medical expense extension per person.

Officials: A maximum of 100 officials officiating in various events across the Country on a given

day are covered for Personal Accident Insurance for Rs.25 lakhs with Rs.1 lakh medical expense extension per person.

Additional Insurance taken by the Organizers (if any):
Public Liability : 50,00,000/-

5.2 Exclusion of Insurance Cover

The service vehicles, management vehicles and reconnaissance vehicles including those bearing special plates issued by the organisers may never be considered as official participants in the rally. They are therefore not covered by the insurance policy of the rally and will remain the sole responsibility of their owner.

5.3 Accident Reporting

In the event of an accident on a Special Stage, the competitor or his / her representative must notify the next radio point. If it is during a transport / liaison section, the competitor or his representative must inform the COC in writing within 4 hours with full details including the names and addresses of those involved and any witnesses.

5.4 Rally Cover Insurance

The competing cars must carry Rally Cover Insurance valid for 12TH, 13TH & 14TH of JUNE 2015.

6. Advertising and Identification

6.1 Advertising is permitted on the car, including the roof. Advertising on windows is prohibited with the exception of a maximum 10 cm wide strip on the upper part of the windscreen and rear window.

6.2 Competitors are allowed to affix any kind of advertisements on their car provided that.

- It is authorized by the National Laws and FMSCI Regulations.
- It is not likely to cause any offense.
- It is not Political or religious in nature.
- It does not encroach upon the space reserved for plates & competition number.

6.3 Optional Advertising is as per Appendix 5. Space for the Organizer's advertisement must be reserved on the car, unless the higher entry fees as per Art. 4.4 are paid.

7. Tyres

7.2 Tyres specified for use during the rally

All tyres shall conform to Appendix IV of FMSCI General Prescriptions.

8. Fuel

Free as per 2015 IRC Specific Technical Regulations.

9. Reconnaissance

9.1 Procedure for Registration

Crews must report to Rally HQ for registration prior to commencing reconnaissance. They must submit details of the reconnaissance car.

Each crew will be issued with two vehicle identification cards which must be displayed on the top of the co-driver's side of the front windscreen and on the co-driver's rear side window during reconnaissance, and a pass valid for up to TWO passages over each special stage. This pass must be carried in the reconnaissance vehicle, shown to and endorsed by an official at the start and finish of each special stage during reconnaissance.

9.2 Restrictions

- 9.2.1 For all competitors reconnaissance will be carried out in accordance with the FMSCI 2015 General Prescriptions with a maximum of 2 passes over every stage in accordance with the reconnaissance schedule given in Appendix 2.
- 9.2.2 Reconnaissance outside the schedule will be considered a very serious offence and will be reported to the Stewards who may apply sanctions.
- 9.2.3 Reconnaissance will be conducted strictly in accordance with the published schedule. No late entry into a stage for reconnaissance will be permitted.
- 9.2.4 Maximum speed allowed on all special stages during reconnaissance is 45 Kph except Super Special Stage.
- 9.2.5 Crews must have the vehicle headlamps switched on while travelling on special stages during reconnaissance.
- 9.2.6 Crews are only permitted to enter a special stage from the start points shown in the road book and will NOT under any circumstances drive in a direction opposite to that of the rally, unless instructed by an official of the event.
- 9.2.7 Crews must stop at the Start and Finish (and other locations where instructed) of the stage where rally official will endorse the crew's reconnaissance pass card.
- 9.2.8 Penalties for excessive speed
Refer Art.20.2 of the 2015 FMSCI General Prescriptions.

Speeding during reconnaissance will incur a fine applied by the clerk of the course as follows

Per Kilometer per hour over the limit.

A & B Seeded Drivers Rs.10,000/-

C seeded drivers Rs.5,000/-

Other traffic infringements during reconnaissance will incur a penalty applied by the Clerk of Course according to article 20.4.4.

The amount of fine will be unaltered by any fine imposed by Police.

Fine will be doubled in case of second offense committed during reconnaissance of the same rally.

10. Administrative Checks

10.1 To be presented at Documentation

- 2015 FMSCI Entrants License
- 2015 FMSCI Driver and Co-Drivers Competition Licenses
- Valid Driver & Co-Drivers Driving Licenses
- Valid Vehicle Registration Papers
- Valid Special Rally Insurance
- Three recent identity photos (4 cm x 4 cm each) of Driver and Co-Driver
- Details Concerning Reconnaissance Vehicle.
- Medical History form
- A letter of authority from the owner of the vehicle if the vehicle is not in competitors name
- Self attested Photocopy of PAN card.

COMPETITORS ARE REQUIRED TO HOLD ADMINISTRATIVE CLEARANCE PASS PRIOR TO SCRUTINEERING

10.2 Time Table

Venue : THE GATEWAY HOTEL.

Date : THURSDAY 11, JUNE 2015 From : 05:30 hrs To : 10:30 hrs

To assist competitors, administrative checks may be completed before these times at the Rally HQ by prior appointment during Rally HQ hours.

11. Scrutineering, Sealing and Marking

11.1 Scrutineering Venue & Time Table

Administrative Checks must be completed and competition numbers, rally plates and advertising decals shall be affixed on the car before entering the scrutineering venue.

Venue : CITY CENTRE MALL, NASHIK.

Date : THURSDAY 11, JUNE 2015

Competition Nos.	Time (hrs)	Competition Nos.	Time (hrs)
30 - 26	06:00 - 06:45	25 - 21	06:45 - 07:30
20 - 16	07:30 - 08:15	15 - 11	08:15 - 09:00
10 - 06	09:00 - 09:45	05 - 01	09:45 - 10:30
	From - To		From - To

Competing crews can send their vehicles for pre event scrutiny with their representatives, who must be carrying an authorization letter from the Crew member.

11.2 Mud Flaps

Mud flaps must comply with Art 252.7.7 of the 2015 FMSCI Technical Regulations for 4W. Missing or ineffective mud flap will incur a penalty @ Rs. 1000/- per mud flap.

11.3 Windows / Nets

Windows must comply with Art.253.11 (Safety Equipment) of the 2015 FMSCI Technical Regulations for 4W.

11.4 Drivers Safety Equipment

Safety Equipments should comply with 2015 FMSCI Safety Requirements and will be checked at Pre-event scrutineering.

11.5 Noise level

Not Applicable

11.6 Special National Requirement

NIL

12. Other Procedures

12.1 Ceremonial Start Procedures and Order

Place : CITY CENTRE MALL, NASHIK

Date : THURSDAY 11, JUNE 2015

All crews in their driving suits or team attire must participate in the Ceremonial Start at 18:30 hrs. on THURSDAY 11, JUNE 2015. Casual dressing is strictly NOT permitted. The team attire is considered only if it has branding of team on it. Any competitor failing to participate and/or failing to follow the dress code will be referred to the stewards for sanction.

A Pre-event holding area, open from 17:30 hrs. will be along side of the Mall. Competitors will gather for group photograph at 18:10 hrs. The National Anthem will start at 18:20 hrs. Spectators will be allowed to take photographs of the cars and competitors are requested to cooperate and support the enthusiasm of spectators. All competing cars must be parked in their allotted space, as guided by the marshals, before 18:00 hrs. Any car reporting outside this time will be penalized at the rate of Rs 500/- per minute up to maximum of 10 minutes before his scheduled start time. Competitor's cars reporting later than 10 minutes prior to their scheduled start time will not take part in the Ceremonial Start and the competitor will be referred to stewards who will impose further sanctions.

All competing cars must be with all stickers on.

The start interval at the Start Ramp will be directed by the Event officials.

12.2 Finish Procedure

Rally will finish at TC 12C. Between TC 12A to TC 12B transit park Ferme will be established at hotel gateway & crews must follow the instructions of officials between these TCs & during the podium finish ceremony. From podium, selected cars are obliged to follow the route described in Informative road book to Final Scrutineering. Rest of the cars will report to Finish Parc Ferme established at City centre Mall, Untawadi Nashik and remain there till Official final classification or instruction by Stewards of the meet.

While the cars are between Podium Finish to Final Scrutineering location they will travel under Parc Ferme regulations and will be observed by marshals.

12.3 Permitted Early Check-in

Early Check-in without incurring any penalty will be permitted at 6E, 9E, 10B, 11A, , 12A, 12C

12.4 Start Procedures

12.4.1 Super Special Stage Procedures

Super Special Stage will run on ASPHALT surface in DADASAHEB PHALKE SMARAK,.

Cars will start in published Start Order in Super Special stage with time interval of 3 minutes between two cars.

As soon as the car finishes the SSS, the time taken by competitor will be calculated at STOP control of SSS. The leading competitor (irrespective of Group / Class) will be asked to remain at interview area erected next to STOP Control. They will take part in promotional activities like signing autograph, do photography session with official cameraman etc. This promotional activity will be done by same competitor till another faster competitor emerges from SS10/SS11/SS12. This process will continue till last car finishes the SS10/SS11/SS12. The competitor waiting in this promotional area will be allotted new start time and they have to reach TC 10A/ in 45min TC 11A /in 05min TC 12A in 12 min.

It is strongly recommended to carry extra lights for the cars as some car may run after sunset and cloudy.

12.4.2 Special Stage Procedure

A photocell will be placed 75 cm from the starting line will be used to detect the jump starts. Should the system fail, the start will be given as per Article 37.2 of 2015 FMSCI General Prescriptions.

12.5 Time Card changes during the rally

Time cards will be exchanged or issued at the following Time Controls:
0A , 3D, 6D, 6F , 9D , 10 ,10B,10E, 12.

12.6 Official Time used during the rally

Official time throughout the entire rally will be that of the GPS time (GMT + 5.30 hrs). This will be displayed at the time of Compulsory Drivers Briefing.

13. Identification of Officials

The Post Chiefs and other officials will be identified as follows:

Safety Marshals	:	Orange Vest
Safety Officer	:	Orange Vest with white stripe and text
Post Chief	:	Blue Vest with white stripe and text
Media	:	Green
Stage Commander	:	Red with text
Competitor Relations Officer	:	Red jacket or red tabard
Medical	:	White
Radio	:	Yellow with blue mark
Scrutineer	:	Black

14. Prizes

Venue : THE GATEWAY HOTEL, NASHIK

Pos	1 st	2 nd	3 rd
IRC	` 60000/- +Trophies	` 40000/- +Trophies	` 30000/- + Trophies
IRC 2000 cc **	` 40000/- + Trophies	` 30000/- + Trophies	` 20000/- + Trophies
IRC 1600 cc **	` 50000/- + Trophies	` 30000/- + Trophies	` 20000/- + Trophies
FMSCI 1600 Cup **	` 40000/- + Trophies	` 30000/- + Trophies	` 20000/- + Trophies

** Number Of Entries : 1 - 4 : 1st Prize Only
 Number Of Entries : 5 - 7 : 1st And 2nd Prizes Only
 Number Of Entries : 8 And Above : 1st, 2nd And 3rd Prizes

Tuner of IRC Trophy
 Tuner of IRC 2000 Trophy
 Tuner of IRC 1600 Trophy
 Tuner of 1600 Cup Trophy

15. Final Checks

15.1 Venue, Date, Time

Venue : CITY CENTRE MALL, UNTAWADI NASHIK.
 Date : SUNDAY 14TH JUNE 2015
 Time : 13:15 hrs

A representative of the entrant as well as mechanics with appropriate tools (in case of dismantling) must be present at the final check.

15.2 Protest Fees

The Protest Fees set by the FMSCI is Rs.18,000/=

15.2.1 If the protest requires the dismantling and re-assembly of different parts of a car, the protestor must lodge an additional deposit.

The additional deposit for a protest involving a clearly defined part of the car (engine, transmission, steering, braking system, electrical installation, bodywork, etc.) Rs. 6000/=.

15.2.2 The expenses incurred in the work and in the transport of the car shall be borne by the claimant if the protest is unfounded, or by the competitor against whom the protest is lodged if it is upheld.

15.2.3 If the protest is unfounded, and if the expenses incurred by the protest (scrutineering, transport, etc.) are higher than the amount of the deposit, the difference shall be borne by the claimant. Conversely, if the expenses are less, the difference shall be returned.

15.3 Appeals

The Appeal Fees set by the FMSCI is

Intention to Appeal : Rs.48,000/=

Appeal Fees : Rs.48,000/=

Appendix 1 - Itinerary

The itinerary as published in the road book will be the definitive itinerary

Start LEG 1		Friday 12 June 2015		Sunrise: 06:03		Sunset: 19:14	
TC /SS	Location	SS Dist	Liaison Dist	Total Dist	Target Time	Av. Speed	1st Car Due
0A	City Centre Mall Park Ferme						6:30
1	Manhere		68.12	68.12	1:40	40.87	8:10
SS1	Manhere 1	12.40					8:13
2	Windmills		8.04	20.44	0:40	30.66	8:53
SS2	Windmills 1	10.09					8:56
3	Ambegao		37.25	47.34	1:10	40.58	10:06
SS3	Ambegao 1	14.30					10:09
3A	Holding zone IN : Hotel GreenLand		14.44	28.74	0:45	38.32	10:54
3B	Holding zone OUT / Service A IN	30min max for any car					10:54
Service A - Hotel Green Land, Igatpuri		36.79	127.85	164.64	0:30		
3C	Service A Exit / Post Service Regroup IN	-	-	-	-		11:24
Restart LEG 1		Friday 12 June 2015		Sunrise: 06:03		Sunset: 19:14	
3D	Regroup OUT				0:40		12:04
RZ1	Refuel- All competitors Distance to Next Refuel	(36.79)	(110.97)	(147.76)			
4	Manhere		51.24	51.24	1:15	40.99	13:19
SS4	Manhere2	12.40					13:22
5	Windmills		8.04	20.44	0:40	30.66	14:02
SS5	Windmills 2	10.09					14:05
6	Ambegao		37.25	47.34	1:10	40.58	15:15
SS6	Ambegao 2	14.30					15:18
6A	Holding zone IN : Hotel GreenLand		14.44	28.74	0:45	38.32	16:03
6B	Holding zone OUT / Service B IN	45 min max for any car					16:03
Service B - Hotel Green Land, Igatpuri		36.79	110.97	147.76	0:45		
6C	Service B Exit / Post Service Regroup IN	-	-	-	-		16:48
Restart LEG 1		Friday 12 June 2015		Sunrise: 06:03		Sunset: 19:14	
6D	Regroup OUT				0:10		16:58
RZ2	Refuel- All competitors Distance to Next Refuel	(36.79)	(127.85)	(164.64)			
6E	Overnight Parc Ferme IN - City Centre Mall		45.98	45.98	1:15	36.78	18:03
LEG 1 Totals		73.58	238.82	312.40			

Appendix 1 - Itinerary

The itinerary as published in the road book will be the definitive itinerary

Start LEG 1		Friday 12 June 2015			Sunrise: 06:03		Sunset: 19:14	
TC /SS	Location	SS Dist	Liaison Dist	Total Dist	Target Time	Av. Speed	1st Car Due	
0A	City Centre Mall Park Ferme						6:30	Sec 1
1	Manhere		68.12	68.12	1:40	40.87	8:10	
SS1	Manhere 1	12.40					8:13	
			2.44	14.84				
RZ 1	Refuel- All competitors Distance to Next Refuel	(24.39)	(57.29)	(81.68)				
2	Windmills		5.60	5.60	0:40	30.66	8:53	
SS2	Windmills 1	10.09					8:56	
3	Ambegao		37.25	47.34	1:10	40.58	10:06	
SS3	Ambegao 1	14.30					10:09	
3A	Holding zone IN : Hotel GreenLand		14.44	28.74	0:45	38.32	10:54	
3B	Holding zone OUT / Service A IN	30min max for any car					10:54	
	Service A - Hotel Green Land, Igatpuri	36.79	127.85	164.64	0:30			
3C	Service A Exit / Post Service Regroup IN	-	-	-	-		11:24	
Restart LEG 1		Friday 12 June 2015			Sunrise: 06:03		Sunset: 19:14	
3D	Regroup OUT				0:40		12:04	Sec 2
RZ 2	Refuel- All competitors Distance to Next Refuel	(12.40)	(53.68)	(66.08)				
4	Manhere		51.24	51.24	1:15	40.99	13:19	
SS4	Manhere2	12.40					13:22	
			2.44	14.84				
RZ 3	Refuel- All competitors Distance to Next Refuel	(24.39)	(57.29)	(81.68)				
5	Windmills		5.60	5.60	0:40	30.66	14:02	
SS5	Windmills 2	10.09					14:05	
6	Ambegao		37.25	47.34	1:10	40.58	15:15	
SS6	Ambegao 2	14.30					15:18	
6A	Holding zone IN : Hotel GreenLand		14.44	28.74	0:45	38.32	16:03	
6B	Holding zone OUT / Service B IN	45 min max for any car					16:03	
	Service B - Hotel Green Land, Igatpuri	36.79	110.97	147.76	0:45			
6C	Service B Exit / Post Service Regroup IN	-	-	-	-		16:48	
Restart LEG 1		Friday 12 June 2015			Sunrise: 06:03		Sunset: 19:14	
6D	Regroup OUT				0:10		16:58	Sec 3
RZ 3	Refuel- All competitors Distance to Next Refuel	(12.40)	(116.54)	(128.94)				
6E	Overnight Parc Ferme IN - City Centre Mall		45.98	45.98	1:15	36.78	18:03	
LEG 1 Totals		73.58	170.22	243.80				

Appendix 1 - Itinerary

The itinerary as published in the road book will be the definitive itinerary

LEG 2		Saturday 13 June 2015		Sunrise: 06:03 Sunset: 19:14			
TC /SS	Location	SS Dist	Liaison Dist	Total Dist	Target Time	Av. Speed	1st Car Due
6F	City Centre Mall Park Ferme						8:00
7	Manhere		68.12	68.12	1:15	40.99	9:15
SS7	Manhere3	12.40					9:18
			2.44	14.84			
RZ 4	Refuel- All competitors Distance to Next Refuel	(24.39)	(57.29)	(81.68)			
8	Windmills		5.60	5.60	0:40	30.66	9:58
SS8	Windmills3	10.09					10:01
9	Ambegao		37.25	47.34	1:10	40.58	11:11
SS9	Ambegao 3	14.30					11:14
9A	Holding zone IN : Hotel GreenLand		14.44	28.74	0:45	38.32	11:59
9B	Holding zone OUT / Service C IN	30 min max for any car					11:59
	Service C - Hotel Green Land, Igatpuri	36.79	127.85	164.64	0:30		
9C	Service C Exit / Post Service Regroup IN	-	-	-	-		12:29
Restart LEG 2 Saturday 13 June 2015							
9D	Regroup OUT				1:20		13:49
RZ 5	Refuel- All competitors Distance to Next Refuel	-	-	-			
9E	Dadasaheb Phalke Smarak Parc Ferme In		39.27	39.27	1:00	39.27	14:49
Restart LEG 2 Saturday 13 June 2015							
10	Dadasaheb Phalke Smarak / Parc Ferme Out				0:30		15:19
SS10	SSS1	2.03					15:22
10A	Overnight Park Ferme IN - City Centre Mall		7.04	9.07	0:45	12.09	16:04
Restart LEG 2 Sunday, 14 June 2015		Sunrise: 06:03 Sunset: 19:15					
TC /SS	Location	SS Dist	Liaison Dist	Total Dist	Target Time	Av. Speed	1st Car Due
10B	Holding zone IN : City Centre Mall		0.20	0.20	0:05	2.40	7:30
10C	Holding zone OUT / Service D IN	30 min max for any car					7:30
	Service D - City Centre Mall	2.03	46.51	48.54	0:30		
10D	Service D Exit / Post Service Regroup IN	-	-	-	-		8:00
Restart LEG 2 Sunday, 14 June 2015		Sunrise: 06:03 Sunset: 19:15					
10E	Regroup Out				0:40		8:40
11	Dadasaheb Phalke Smarak		6.62	6.62	0:20	15.89	9:00
SS11	SSS2	2.03					9:03
11A	Dadasaheb Phalke Smarak Parc Ferme In		0.22	2.25	0:05	27.00	9:05
Restart LEG 2 Sunday, 14 June 2015		Sunrise: 06:03 Sunset: 19:15					
12	Dadasaheb Phalke Smarak / Parc Ferme Out				1:40		10:45
SS12	SSS3	2.03					10:48
12A	Transit Parc Ferme In - The Gateway Hotel		3.12	5.15	0:12	61.80	10:57
Restart LEG 2 Sunday, 14 June 2015		Sunrise: 06:03 Sunset: 19:15					
12B	Transit Parc Ferme Out - The Gateway Hotel				0:30		11:27
12C	Finish Park ferme In- City Centre Mall		4.62	4.62	0:25	11.09	11:52
LEG 2 Total		42.88	184.32	227.20			
Total of Rally							
		SS	LIASON	TOTAL	# %	* %	
	LEG 1 - 6 SS	73.58	170.22	243.80	43.23%	30.18%	
	LEG 2 - 6 SS	42.88	184.32	227.20	23.26%	18.87%	
	TOTAL - 12 SS	116.46	354.54	471.00	32.85%	24.73%	
		# % The percentage of Day's distance of special stage					
		* % The percentage of total distance of special stage					

Appendix 2 – Reconnaissance Schedule

The normal time taken from the Rally HQ to SS No.1 is approximately 90 Minutes. Distance to travel is 68.12 kms.

SS No.	SS Distance (Kms)	THURSDAY 11 JUNE 2015	Time Opens	Time Closes
1/4/7	12.40	1 st Pass	06:00 hrs	06:45 hrs
		2 nd Pass	10:15 hrs	11:00 hrs
2/5/8	10.09	1 st Pass	06:45 hrs	07:30 hrs
		2 nd Pass	11:00 hrs	11:45 hrs
3/6/9	14.30	1 st Pass	08:00 hrs	08:45 hrs
		2 nd Pass	12:15 hrs	13:00 hrs

SS No.	SS Distance (Kms)	THURSDAY 11 JUNE 2015	Time Opens	Time Closes
10/11/12	2.03	1 st Pass	14:30 hrs	15:00 hrs
		2 nd Pass	15:00 hrs	15:30 hrs
		1 st Pass	hrs	hrs
		2 nd Pass	hrs	hrs
		1 st Pass	hrs	hrs
		2 nd Pass	hrs	hrs

Appendix 3 – Competitors Relations Officer(s) Itinerary and Photograph

	
<p>KAILASH GURNANI 8888433533 gurnani.kailash@gmail.com</p>	<p>KAUSTUBH MACHHE 9960001955 its_ur_kaustubh@gmail.com</p>

A CRO will be in attendance as follows:

WEDNESDAY 10 JUNE 2015	Administrative Checking Rally HQ
THURSDAY, 11, JUNE 2015	Reconnaissance
	Compulsory Drivers Briefing
	Pre Event Press Conference
	Ceremonial Start
FRIDAY, 12, JUNE 2015	Start at City Centre Mall
	Service Park at Hotel Greenland
SATURDAY, 13, JUNE 2015	Start at City Centre Mall
	Service Park at Hotel Greenland
	Service Park at City Centre Mall
SUNDAY, 14, JUNE 2015	Start at City Centre Mall
	Podium Finish at The Gateway Hotel
	Post Event Press Conference
	Rally HQ

Appendix 4.1 – Compulsory Advertisement

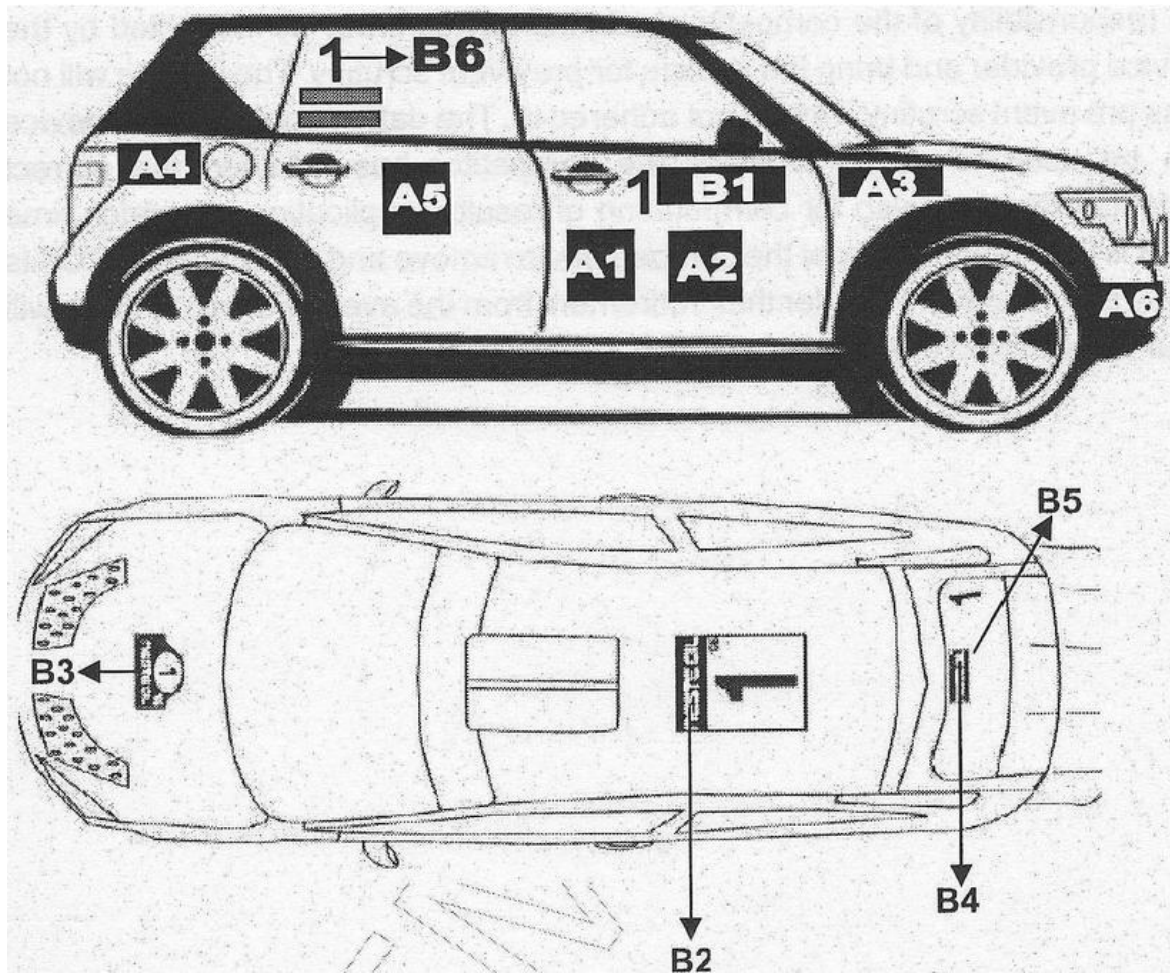

B1	:	Front Door Panel	:	67 cm X 17 cm
B2	:	Roof Panel	:	50 cm X 52 cm
B3	:	Bonnet Panel	:	43 cm X 21.5 cm
B4	:	Rear Window Panel	:	30 cm X 10 cm
B5	:		:	15 cm X 14 cm
B6	:	Side Window Panel	:	25 cm (Stroke Width 25 mm)

Appendix 4.2 – Optional Advertisement

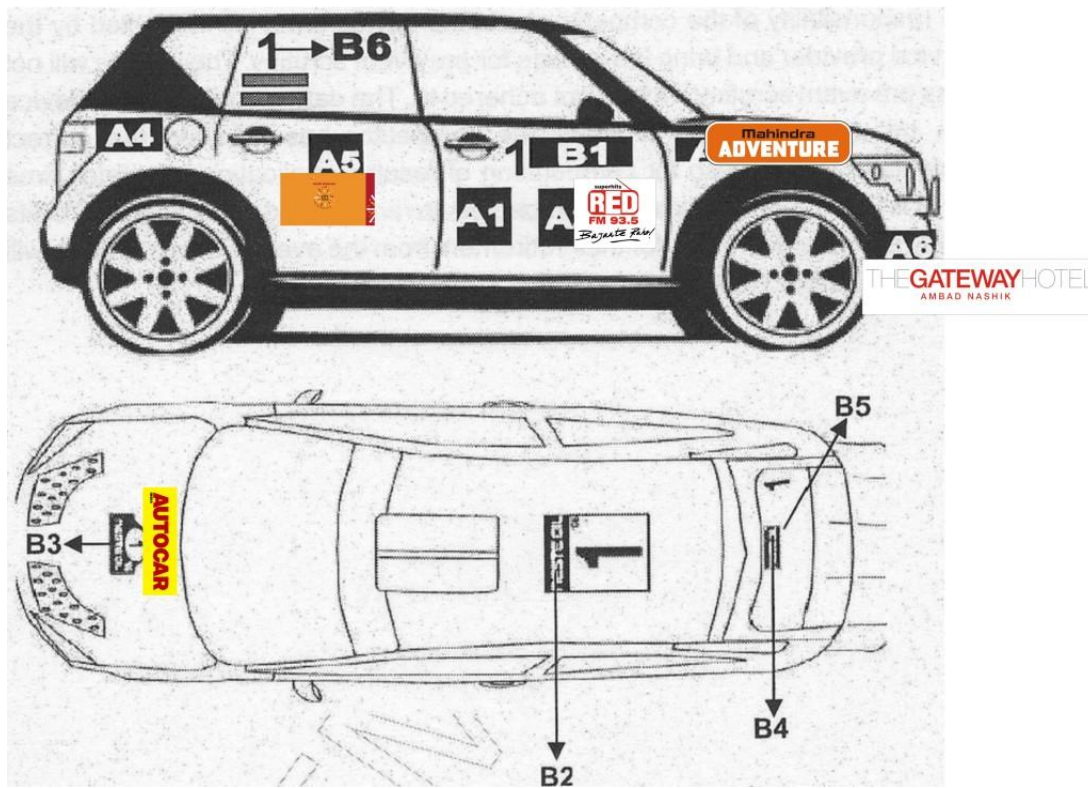

- A1 : T.B.A
- A2 : Red FM
- A3 : Mahindra Adventure
- A4 : T.B.A
- A5 : City Center Mall
- A6 : The Gateway hotel
- A7 : Autocar

Appendix 5 – Any Other

- The Service Park D is located in shopping mall at first floor parking.
- The surface will be concrete.
- The bay size will be (W) 2.5 m X (L) 6.5 m X (H) 2.4 m
- The heavy vehicle or LCV will not be permitted in Service Park (Service D.)
- The transport of spares required can be done with small pickup vehicles from GFL to First floor Service Park (Service D).
- The food court will be located at 3rd floor and all crews will need to encash coupons at food court only.
- In the non working hours of the Service Park the spares must be taken out and organisers or mall management will hold no responsibility of it.
- It is recommended that you carry flexible lighting to work on vehicles.
- No trailers can be parked near Service Park(Service D).
- All bays must be cleaned and use of tarpaulin or plastic paper bellow car is mandatory.
- Crews will have to ensure that the bays are cleaned before they leave mall (Service D) on every day. Cleaning agency will be provided by organisers.
- Refuel zone will not be located at Service park in City Centre MALL.
(Service D).
- Main service park (service A, B, C) Located at Hotel Green Land, Igatpuri.
- All crews will need to encash coupons in the restaurant at Hotel Greenland.
- Those competitors who wish to take service on Sunday, 14th June 2015, Should inform rally secreatriat on or before 21:00 hrs on Saturday 13th June 2015.

-